

EXHIBITOR REGISTRATION FORM: WINES FROM SPAIN

10th Annual Miami International Wine Fair
 September 23-25, 2011 – Miami Beach Convention Center



INSTRUCTIONS:

1. Click on each field below to enter the information requested
2. When completed Save and Email this form to exhibitor@miamiwinefair.com
3. Print completed form, Sign it and fax it to 1-866-229-3031

Company Name:

Contact Name: Title:

Address: Suite/Office:

City: State/Province:

Country: Postal Code:

Telephone: Fax: E-mail:

Local Contact (if any): Title:

Telephone: E-mail:

Types of products to be displayed: *(check all that apply)*

- WINE SPIRITS FOOD ACCESSORIES MAGAZINE TRAVEL

Country of origin (list all):

2011 FLOORPLAN - HALL A - MIAMI BEACH CONVENTION CENTER

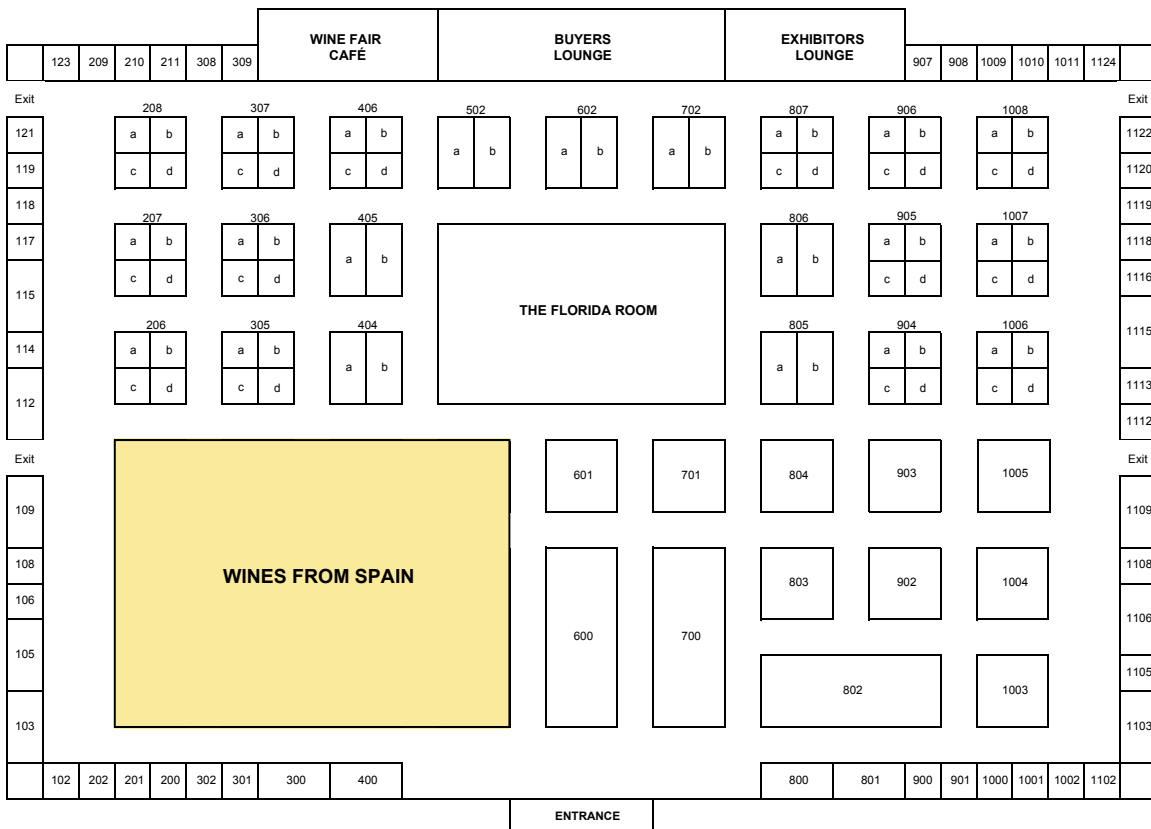

EXHIBITOR PACKAGES

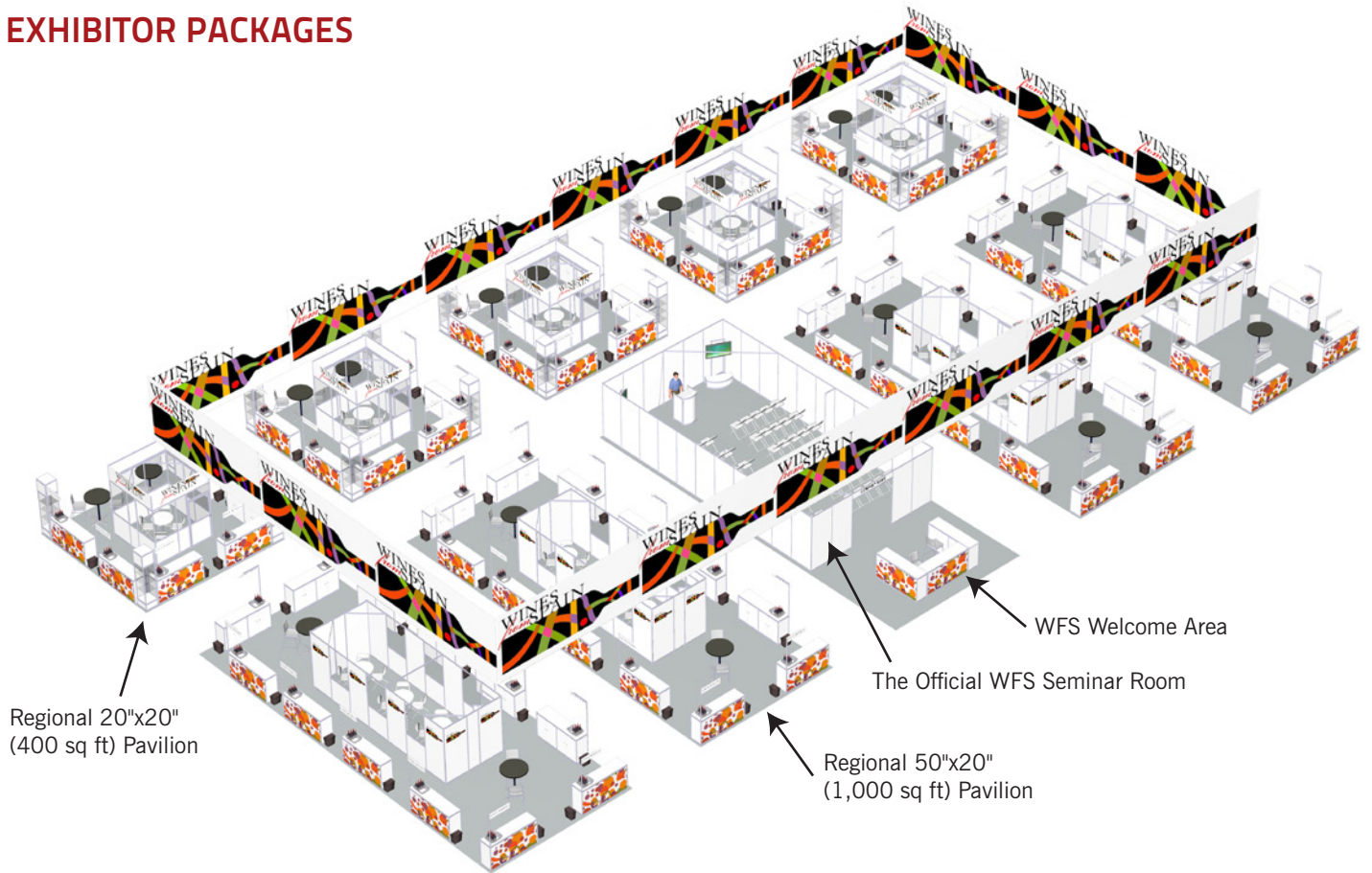

Regional 20"x20"
(400 sq ft) Pavilion

WFS Welcome Area

The Official WFS Seminar Room

Regional 50"x20"
(1,000 sq ft) Pavilion

Every 6-ft table in any package includes, signage, ice tray, water pitcher, ice and water service for the duration of the show, spittoon, napkins, garbage can, and two chairs. Carpeting is included.

BASIC - \$2,100

65-85 sqft. in a shared 50x20 pavilion.
Access to a common meeting area.
Includes 1 Standard program listing.



20 X 20 DELUXE PAVILION - \$17,500

400 sqft pavilion with 6, 6' tasting tables, two cocktail tables, four bar stools, a private meeting room with 1 round table and four chairs and carpeting.
1 Deluxe and 6 Standard listings included.

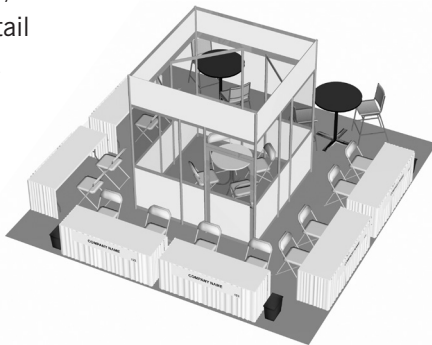

50 X 20 DELUXE PAVILION - \$39,500

1,000 sqft pavilion with 12, 6' tasting tables, a private meeting room with 3 round tables and 12 chairs. This package also features, 2 cocktail tables, 4 bar stools and carpeting. 1 Deluxe and 12 Standard listings included

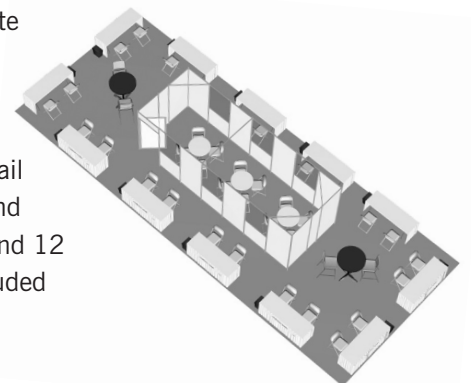

EXHIBITING OPTIONS, ACCESSORIES & SEMINARS

(Note: Tasting floor will be open only on Sep 24th and 25th)

PACKAGES	6 FT TABLES	FT ²	PROGRAM LISTING ¹	PRICE	#	SUBTOTAL
BASIC	1	65-85 ⁺	STANDARD	\$2,100		
20 X 20 DELUXE PAVILION	6	400	DELUXE	\$17,500		
50 X 20 DELUXE PAVILION	12	1000	DELUXE	\$39,500		
	(REQUIRED) Booth Cleaning Services ²			\$75 / table		
	Additional Standard Program Listing ¹			\$100		
	Additional or Upgrade for Deluxe Program Listing ¹			\$250		
	Glassware ³			\$100		
	Electrical Outlet ⁴			\$125		
	Bilingual Hostess / Model (8 hrs X 2 days)			\$650		
SEMINARS (Friday, Sep 23rd)	What Sells in America			\$125		
	The Three Tier System			\$275		
	Introducing your Wines to the US Market			\$195		
	Opportunities in Latin America & The Caribbean			\$275		
	Latest Trends in the U.S. Retail Wine Market			\$275		
	SEMINAR PACKAGE (Includes All Friday Seminars)			\$800		
	Walk-Around Tasting (Wineries Seeking Importers)			\$475		
SPECIAL EVENTS	VIP Dinners (Fri, Sep 23rd) ⁵			\$400 / Buyer		
	Networking Dinner (Sat, Sep 24th) ⁶			\$150		
					TOTAL	

FOOTNOTES

- ⁺ One 6ft table in a 50x20 shared pavilion will provide an exhibit space of approximately 65-85 sqft, depending on the number of exhibitors sharing the pavilion.
- ¹ A **Standard** program listing includes your company's name, booth number and contact information in the Fair's official program. A **Deluxe** program listing includes the **Standard** listing details plus your company's LOGO, name in bold, and up to 50 words describing your company.
- ² Includes daily cleaning of your booth and garbage disposal for the duration of the show. The price listed is per 6' table included in your package. e.g., a Premium-level exhibitor would pay \$150 (2 tables X \$75.)
- ³ 18 Stölzle Grandezza 13oz professional wine tasting glasses from Austria. Yours to keep. Access to washing station provided.
- ⁴ This rate is per outlet, located at the back of a booth and only applies to Basic & Premium and their deluxe versions. For all Pavilions, custom rates apply.
- ⁵ Dinner sponsored by your organization. Fee includes services to guarantee the presence of a number of buyers pre-selected based on your specifications. Price does not include the cost of dinner.
- ⁶ Highly recommended. Extraordinary networking opportunity. 100+ VIP buyers in attendance. Includes buffet-style, sit-down dinner with buyers & your wines! Exhibitors may bring 2 wines to the event's open tasting area.

BUYERS PROGRAM

Please include additional information about your wines to help us match you with visitors interested in your products. Meetings or sales are not guaranteed.

Region	Varietal	Price*	States where your product IS distributed <i>(write "none" if you are looking for an importer)</i>

*Target retail price. If you are uncertain, please send us your ex-cellars price and your country of origin to price@miamiwinefair.com and we'll send you the estimated retail price for your wines in the US.

Do you have a US Importer? Yes No

Do you have a Florida distributor? Yes No

States where you are seeking a distributor:

IMPORTANT DISCLAIMER (please read carefully and write your initials at the bottom)

The *Buyers Program* is designed to help every exhibitor meet potential buyers for their products. Participating buyers are required to meet with a minimum of 10 exhibitors during their visit to the Wine Fair. We carefully draft a schedule for every buyer based on their needs and the information you provide about your products, but we can't possibly guarantee that an actual match will occur or that buyers will follow the exact program we prepare for them. To give buyers the freedom they need, their schedules don't have specific meeting times. Please be ready to deal with two or more buyers coming to your booth simultaneously.

Initials:

PAYMENT

TOTAL

Check enclosed

Make check payable to VINTRADE, LLC. EIN: 26-2139767
Mail check to 8101 Biscayne Blvd. Suite 617, Miami, FL 33138

Wire Transfer

Call our office for details: +1-866-887-WINE (9463)

Charge my credit card in the amount of \$ (enter TOTAL)

VISA MASTERCARD Credit Card Number: Expiration Date: Month Year:

Name on Card:

Billing Address: City:

State/Province: Zip Code: Country:

Signature: Title:

Signature and payment must accompany this application in order to be processed. Once your application is received and approved, your company will be assigned exhibit space based on the package requested, product you intend to exhibit, origin, special requirements and space availability. No exhibit space will be assigned prior to receiving payment. VINTRADE is not responsible for generating any business opportunities for companies exhibiting at the Miami International Wine Fair. Cancellations must be received in writing prior to July 15, 2011 to qualify for a full refund minus a \$200 administrative fee. No refunds will be made after this date. VINTRADE, LLC will not be responsible or liable for any event cancellations due to natural disasters, terrorist attacks or war.